

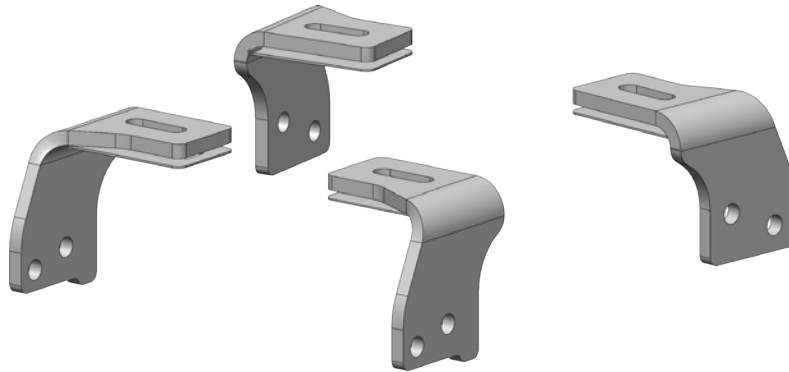

# TOYOTA

## 16K Industry Standard Rail Custom Mounting Kit

# #2748



Gross Trailer Weight (Maximum)..... 16,000 lbs.  
Vertical Load Weight (Max. Pin Weight) ..... 4,000 lbs.

### SYSTEM TOW CAPACITY

Please note, in order to determine the **total tow capacity** of a system, you must consider the weight ratings of each component in that system. This includes, but may not be limited to, the capacity/rating of the **tow vehicle**, the **fifth wheel hitch**, and the hitch's **mounting system**. Actual tow capacity of the system will be equal to the lowest rated component.

---

# Installation Instructions

---

## SPECIFICATIONS

- Fits 2007-2016 Toyota Tundra (*all bed lengths*)
  - King pin is located 1-1/4" ahead of axle
- Custom Mounting Bracket Kit (*Bracket & Hardware*) #2749

# TABLE OF CONTENTS

PLATE ASSEMBLY.....	3
MOUNTING KIT EXPLODED VIEW.....	4
MOUNTING KIT PARTS LIST .....	5
TRUCK PREPARATION.....	6
MARKING THE TRUCK BED FOR DRILLING.....	6
LAYOUT METHOD .....	6
TEMPLATE METHOD .....	7
INSTALLATION .....	8
PART 1 — BRACKET PLACEMENT & BED HOLE LOCATIONS.....	8
PART 2 — MOUNTING BRACKET TABS .....	9
PART 3 — INSTALLING RAILS AND SHIMMING THE BED .....	9
PART 4 — BRACKET INSTALLATION AND DRILLING THE FRAME .....	10
PART 5 — FINAL INSTALLATION PROCEDURES .....	10

# PLATE ASSEMBLY

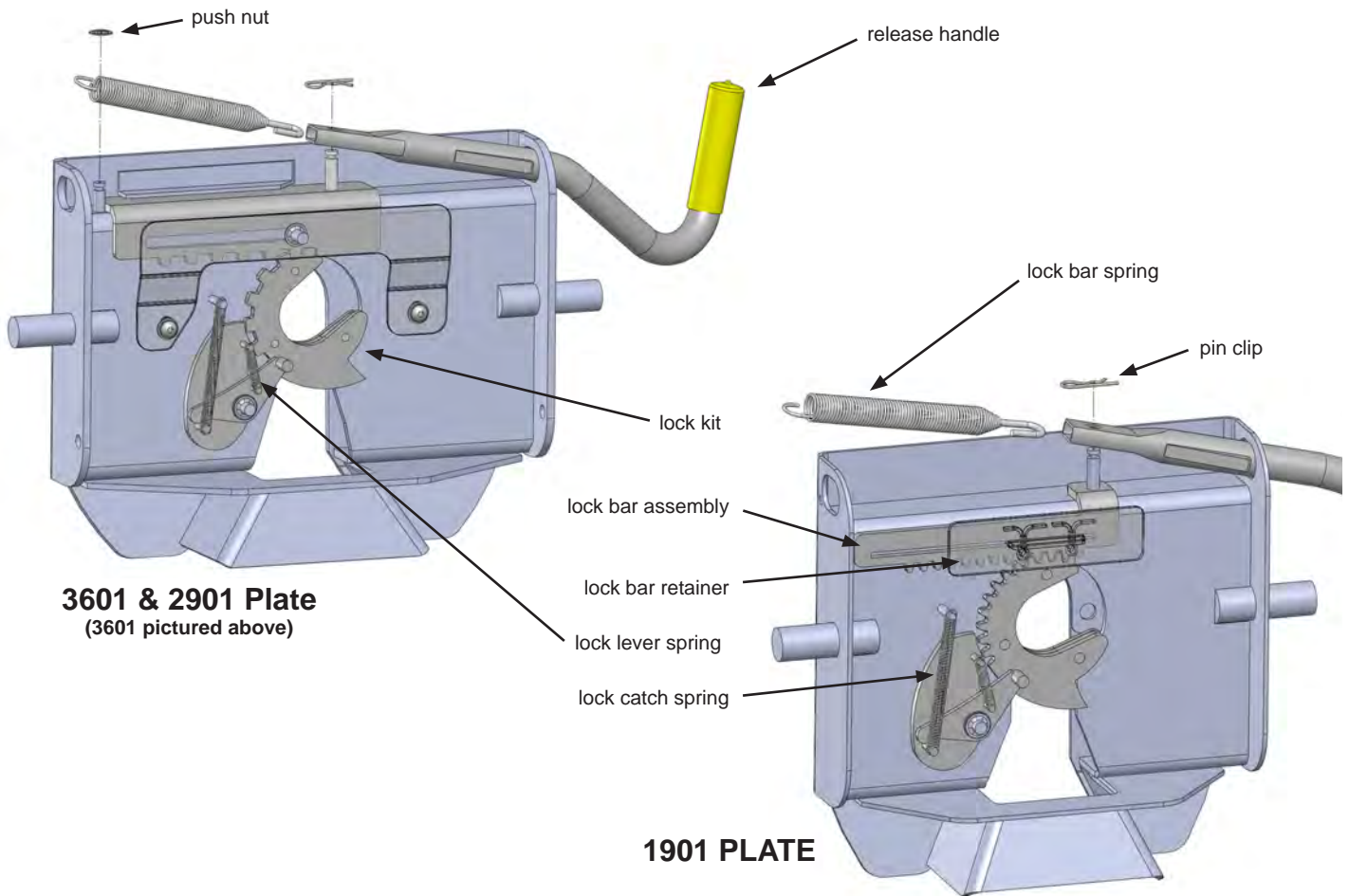

1. Remove the Fifth Wheel Plate from the Rocker Arm and place it upside down on a smooth, clean surface.
2. Insert the Release Handle into the obround hole of the plate as seen above.
3. The Lock Bar Spring must be placed inside the handle prior to placing the handle down over the pin of the Lock Bar Assembly, "catching" the hook inside the handle around the pin.
4. Push the handle and spring assembly down past the groove in the pin of the Lock Bar Assembly, and place one of the Pin Clips in the groove of the pin to fasten.
5. Grip the body of the spring and stretch it far enough over the opposite pin (welded to the plate) and push it down past the groove.
6. Install the Push Nut to secure the Lock Bar Spring onto the welded pin.

**NOTE:** The 1901 plate for the #1900 Super 5<sup>th</sup> does not use a push nut to attach the end of the spring, but rather a slot in the side of the fifth wheel plate located above the obround hole. See illustration to the right.

As a PullRite fifth wheel hitch owner, it is important for you to study and manually operate the Fifth Wheel Plate and Release Handle to better understand the locking action. A better working knowledge of the plate will help prevent accidental dropping of your trailer due to incorrect hitching.

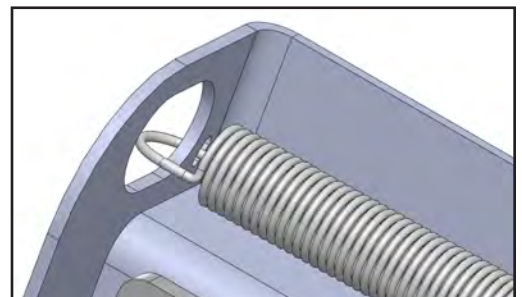

Also, it is imperative that you study and adhere to the Maintenance procedures provided in the Owners Manual. If you did not receive one upon purchase, please contact PullRite or visit us on the web at [www.pullrite.com](http://www.pullrite.com).

# MOUNTING KIT EXPLODED VIEW

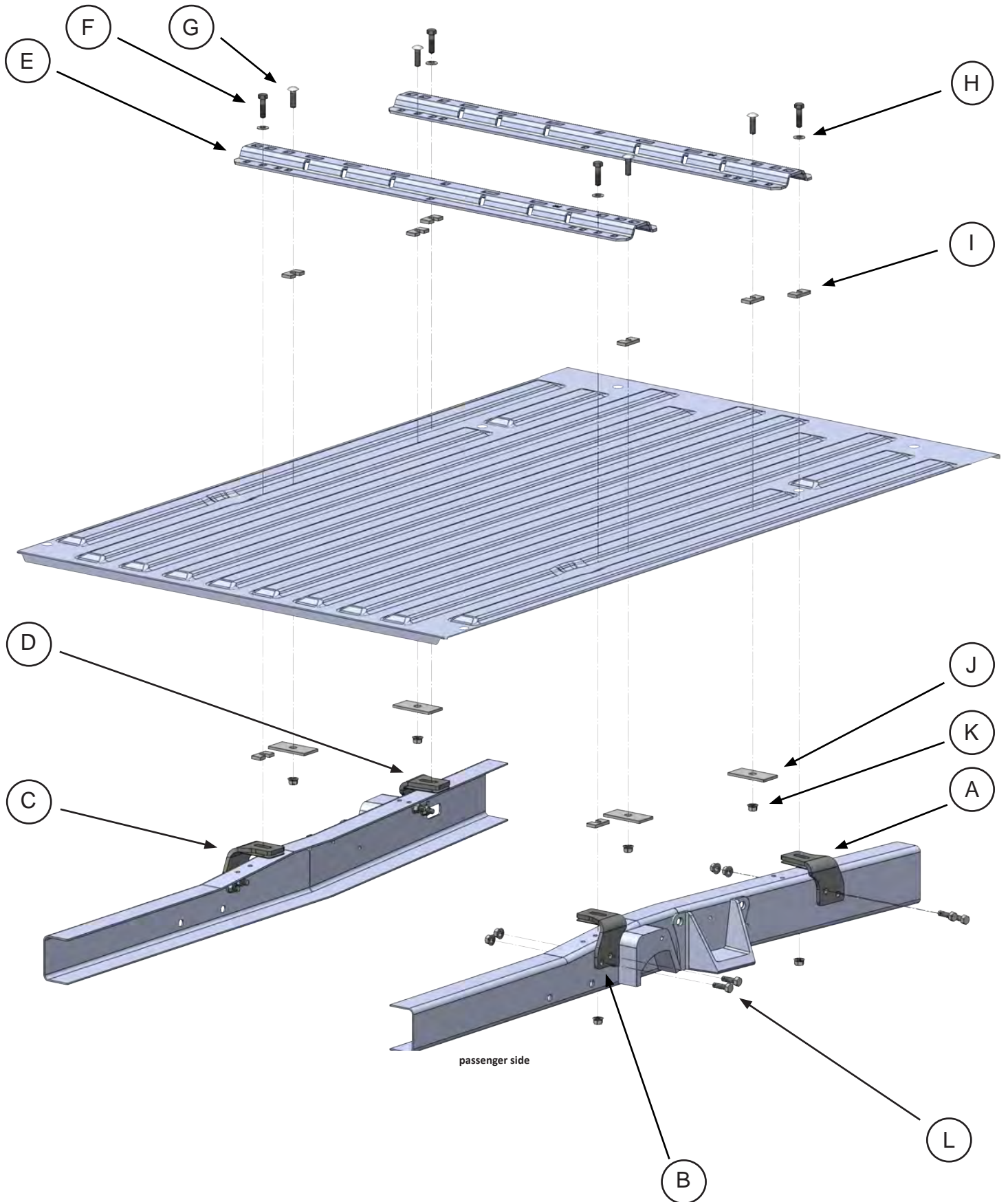

# MOUNTING KIT PARTS LIST

## #2748 TOYOTA CUSTOM ISR BRACKET KIT

description	part no.	qty	material
MOUNTING BRACKET KIT	2749	1	(See kit contents listed below)
BASE RAIL KIT	2719	1	(See kit contents listed below)

### #2749 — MOUNTING BRACKET KIT

item	description	part no.	qty.	material
A	PASSENGER SIDE FRONT MOUNTING BRACKET	274902	1	
B	PASSENGER SIDE REAR MOUNTING BRACKET	274904	1	
C	DRIVER SIDE REAR MOUNTING BRACKET	274903	1	
D	DRIVER SIDE FRONT MOUNTING BRACKET	274901	1	
	MOUNTING BRACKET HARDWARE KIT	274905	1	(See kit contents listed below)

### #274905 — MOUNTING BRACKET HARDWARE KIT

item	description	part no.	qty.	material
F	1/2" BASE RAIL BOLT	98010166	4	1/2"-13 X 1-3/4" HHCS GRD 5
G	1/2" CARRIAGE BASE RAIL BOLT	98050133	4	1/2"-13 X 1-5/8" CARRIAGE BOLT
H	FLAT WASHER	98250145	4	1/2" FLAT WASHER
I	SLOTTED SHIM	08070201	8	5/16" SLOTTED BED SHIM
J	CENTER HOLE BACKUP PLATE	27210203	4	
K	FLANGE NUT	98150201	16	1/2"-13 SERRATED FLANGE NUT
L	1/2" FRAME BOLT	98010167	8	1/2"-13 X 1-1/2" HHCS GRD 5

### #2719 — BASE RAIL KIT

item	description	part no.	qty.	material
E	BASE RAILS	27190001	2	

### LAYOUT TEMPLATE

description	part no.	qty.	material
LAYOUT BED TEMPLATE	27200000	1	<i>ITEM SOLD SEPARATELY</i>

# TRUCK PREPARATION

1. Block vehicle wheels. Some vehicles may require you to raise the rear of the truck to install the mounting brackets on the truck frame.
2. You may wish to remove the wheels to give yourself greater working room.
3. Carefully remove the plastic inner wheel well guards on both sides of the vehicle (*not applicable to some models*).
4. Remove the spare tire. This will allow easy access to the inside of the truck frame. The fender support at the front of the wheel well may also need to be removed in order to drill front hole locations.

## MARKING THE TRUCK BED FOR DRILLING

### LAYOUT METHOD

If you purchased an installation template, please proceed to "TEMPLATE METHOD". *Templates are sold separately.*

1. Referencing "Truck Bed Dimension Table" below, measure and mark from the back of the bed forward, the values for "A." Do this at any point on both sides of the bed and draw a line across the bed from mark to mark.
2. Find the centerline of the bed.
3. Draw a line down the middle of the bed from front-to-rear.
4. Starting at "A," measure from the end of the bed back to the first bolt hole on the base rail (row 4) and mark the bed.
5. Measure the distance of "C" from the centerline of the bed in both directions.
6. Continue working toward the cab, marking the center holes of each remaining bolt location.

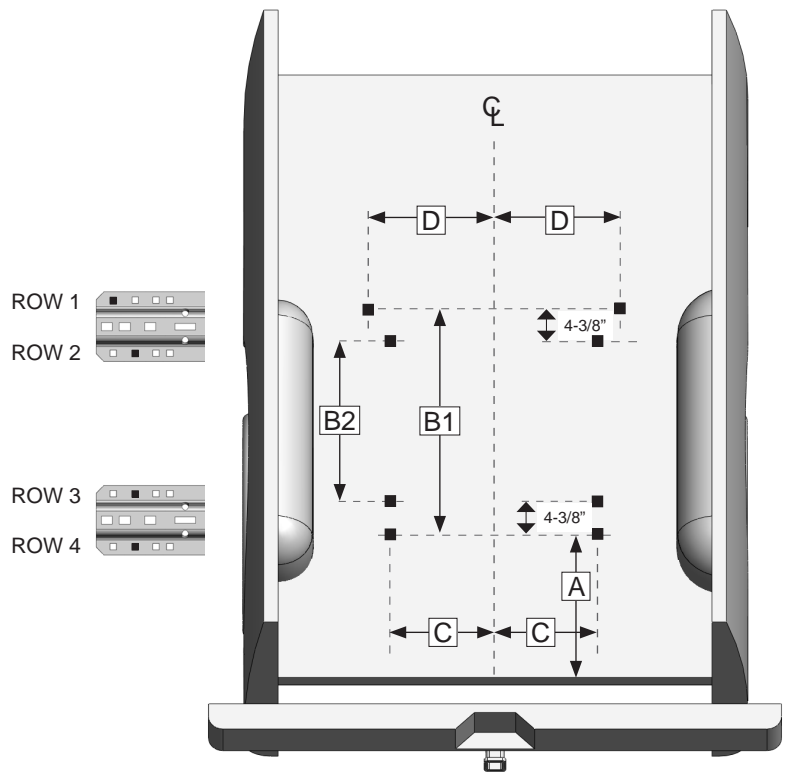

TRUCK BED DIMENSION TABLE						
LAYOUT METHOD				TEMPLATE METHOD		
"A"	"B1"	"B2"	"C"	"D"	"X"	Template part#
28-1/8"	26-5/16"	17-11/16"	18-9/16"	20-3/8"	27-7/16"	27200000

## TEMPLATE METHOD

1. Lay the template in the truck bed, centering it from side-to-side, and parallel to the end of the truck bed using the dimension "X" listed in "Truck Bed Dimension Table."
2. Mark the 8 holes, while making sure the template does not move.

**INSTALLATION TIPS:** The *TEMPLATE* should be orientated as shown in the drawing below. To avoid drilling holes in error from out of tolerance bed-to-frame dimensions, mark the hole locations as lightly as possible if a center or transfer punch is used. Then use a very small diameter drill bit to drill one location on either side of bed. Place the *Mounting Brackets* against the frame to determine the correctness of the bed hole locations relative to the pre-punched holes in the *Mounting Bracket* and existing frame holes. Adjust the template pattern relative to the end of the bed, as necessary, to move the bed holes nearer the center of the mounting bracket holes. Note also, the information etched into the template — the direction of the cab, the template number and the revision date. As one last measure, the template has a tendency to move when placed on the slick paint of new truck beds, and it may be helpful to place a small piece of *NON-SKID* matting, such as "SCOOT-GARD"™ or simply use duct tape on each corner to help keep the template from moving.

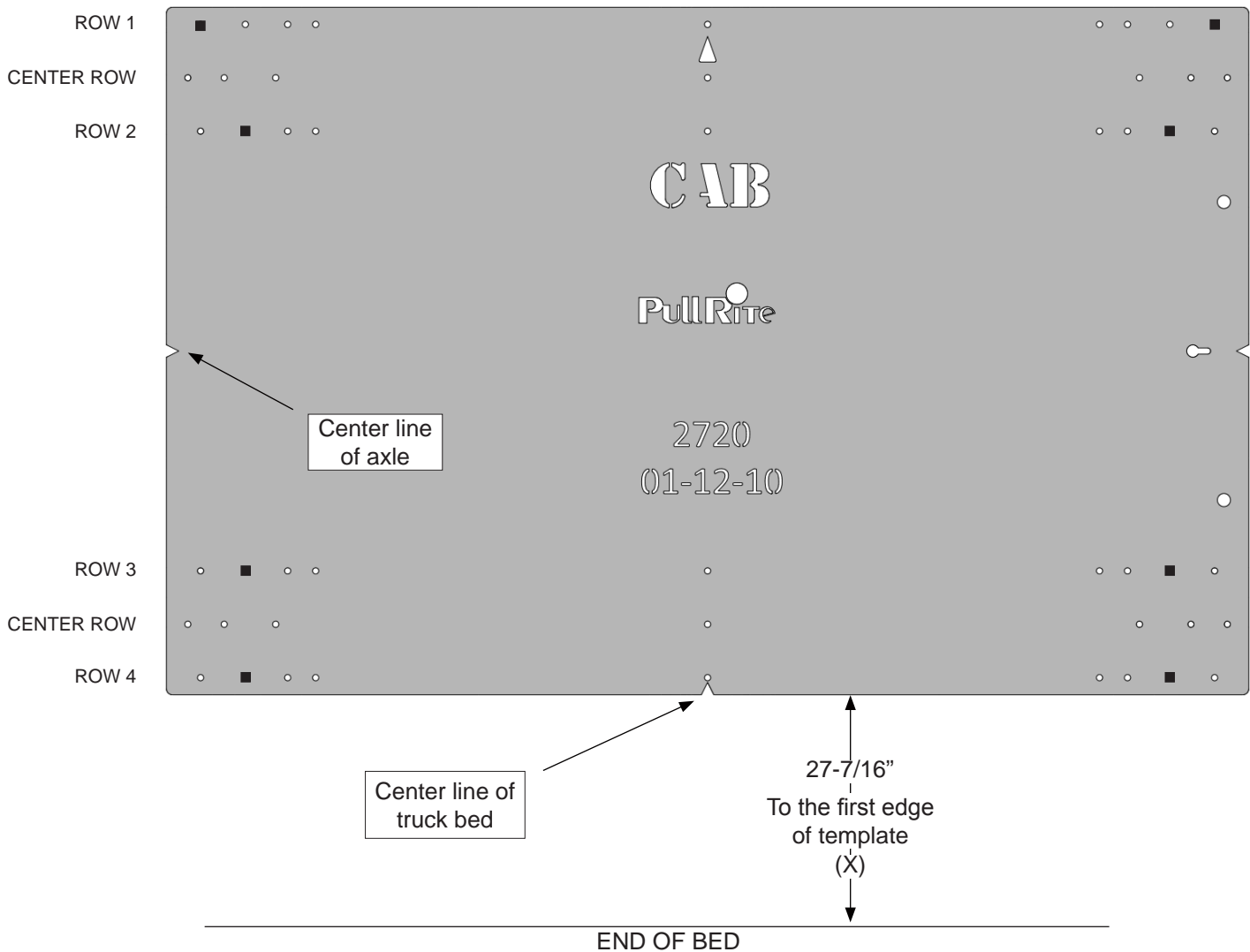

# INSTALLATION

## PART 1 — BRACKET PLACEMENT & BED HOLE LOCATIONS

Since most truck beds are not installed square to the frame or are the same distance from the back of the cab, the installer will need to make sure the bed holes line up properly with the center of each mounting bolt hole.

The basic steps in this section are as follows:

- Layout the bed holes
- Drill the first pilot hole in the bed
- Check centering
- Adjust the bed hole layout if necessary
- Drill the second pilot hole and check centering to ensure bed hole locations are square to the frame; adjust as needed
- Drill remaining pilot holes in the bed; check centering

### Detailed Installation Instructions

1. Position the Passenger Side Rear Mounting Bracket {B} on the frame and clamp in place to determine if your bed layout marks are square to the frame, making sure the bracket is tight against the frame (some mounting brackets may have a slight warp due to the metal characteristics during the welding process).
2. Drill the first 1/16" pilot hole through the truck bed over the slotted bolt hole of {B} where you made the mark during "Marking Bed for Drilling." Keep the drill bit in the pilot hole to aid you in checking for centering front-to-back in the slotted bolt hole of the bracket (*make certain that the mounting bracket does not interfere with the shock tower. If an interference is found, relocate the Industry Standard Rails and bracket rearward until no interference is detected. If you go too far rearward with the mounting bracket, the passenger side rear bracket moves away from the shock tower, and the front drivers' side frame bracket gets closer*).
3. Once the passenger side rear pilot hole is centered properly, drill a 1/16" pilot hole for the *front* bolt hole location on the rail where the carriage bolt {G} will be installed.
4. Repeat Steps 1-3 for the Driver Side Rear Mounting Bracket {C}, checking centering carefully.
5. Once the Rear Mounting Brackets have been properly centered and the pilot hole locations are verified, repeat the previous steps for the Passenger {A} and Driver Side {D} Front Mounting brackets.

**NOTE:** Some truck beds are not installed square on their frame by the manufacturer. To ensure your pilot holes are aligned properly, it is important that you use the measurements provided only as a starting point and make adjustments as needed. Once the rear driver side pilot hole is centered, you will use this hole as a point of reference for all remaining pilot hole adjustments. If you are using the Template Method, simply use the properly drilled hole as a pivot point to square the remaining holes to the frame. If you are using the Layout Method, you may accomplish the same thing by using a framing square and straight edge.

6. Remove all mounting brackets from the frame and drill out all pilot holes with a step drill to a *minimum 9/16" diameter (a step drill is a cone shaped bit that has a variety of gradually larger diameter sizes the deeper the drill is used – see right)*.
7. Remove all drill shavings from the bed and treat the holes with a suitable rust inhibitor.





# INSTALLATION

## PART 2 — MOUNTING BRACKET TABS

1. Examine the Mounting Brackets and note that there is a 1/8" thick tab located just below the slotted bolt hole in the top plate of the Mounting Bracket (see right). The purpose of this tab is to assist you in holding the Flange Nut {K} in place. To install, pry the "tab" down far enough so that a Flange Nut can be inserted, then push the "tab" back up into position. The Flange Nut should be able to slide in and out while the "tab" holds the nut in place. When fastening the Base Rails to the Mounting Brackets, the Flange Nut can easily be positioned under the square hole in the Base Rail using a pen or other small tool. When tightening the Base Rail Bolts with an impact gun, start slowly as the "tab" may otherwise "strip out."

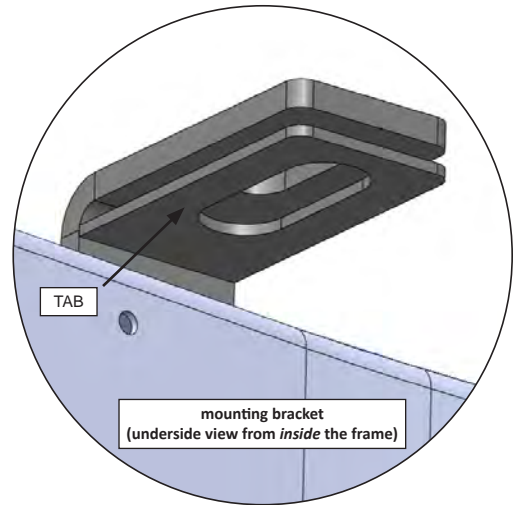

## PART 3 — INSTALLING RAILS AND SHIMMING THE BED

1. Place the Industry Standard Rails into position in the bed.
1. To prevent "crushing" of the corrugated truck bed, we provide Slotted Bed Shims {I} and Center Hole Backup Plate {J} to be installed above and/or below the truck bed where necessary. Not all truck beds are installed exactly the same when manufactured, so it is necessary for you to determine where to place the shims, and their orientation, relative to the bolt locations (see "Layout Method").
2. If you find that a bolt hole location is located over a bed channel, you will need to use a slotted bed shim to fill the space so it is even with the top of the bed. Conversely, do the same if the channel is located on the underside of the bed if necessary.
3. In Part 4 of the installation, you will be putting the rails down in the bed. Refer to the illustration below, so you can shim above the bed if necessary. You will shim under the bed while reinstalling each bracket.

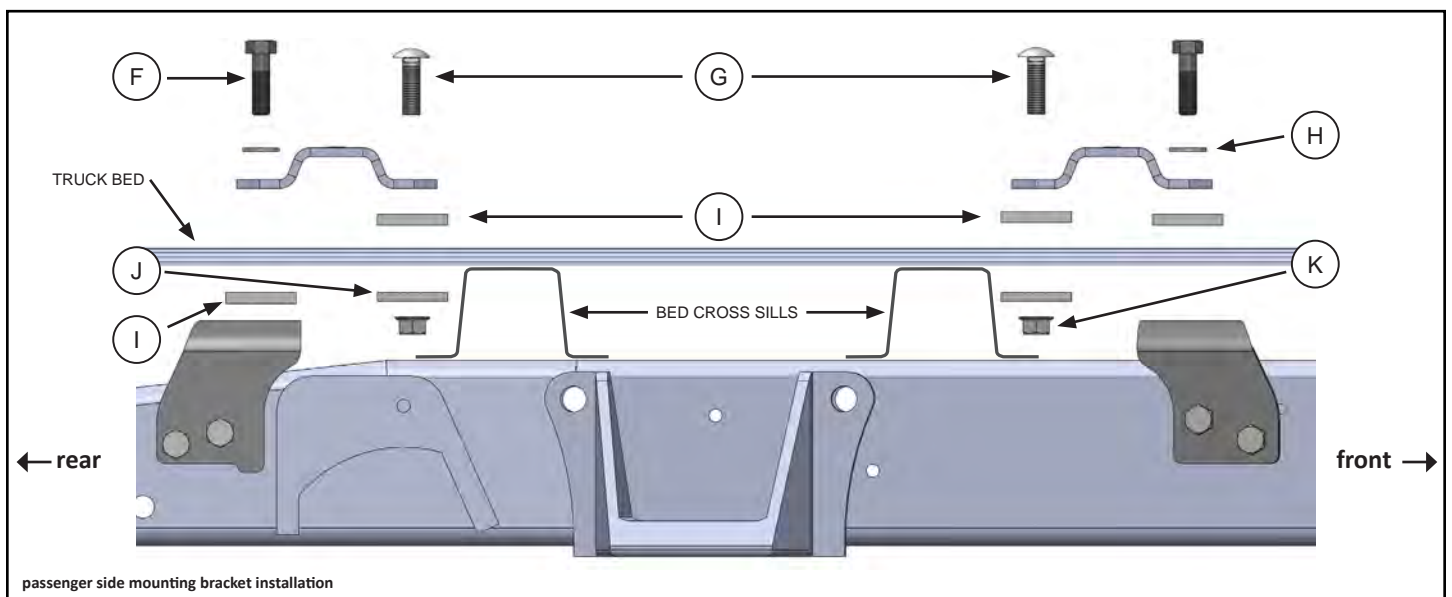

**The above hole, shim and backup plate locations and selection are for illustrative purposes only!  
Shims and backup plates are used to support the truck bed where gaps caused by  
the corrugated truck bed are present between the brackets and base rails.**

# INSTALLATION

## PART 4 — BRACKET INSTALLATION AND DRILLING THE FRAME

1. Install the 1/2" Base Rail Bolt {F} through a base rail and required shims, in position over where the Passenger Side Rear Mounting Bracket {B} will be installed.
2. Reinstall the Passenger Side Rear Mounting Bracket, and bed shims {I} (see PART 3), being careful to center the bolt into the slot of the bracket.
3. Thread a Flange Nut {K} onto the bolt. Finger tighten only.
4. Clamp the bracket in place to the frame.
5. Using the bracket holes as a guide, drill a 1/2" diameter hole through the truck's frame.
6. Install the 1/2" Frame Bolts {L} through the bracket and frame and secure with a Flange Nut.
7. Repeat steps 1-6 for all remaining Mounting Brackets.
8. Install all Carriage Bolts {G} and Center Hole Backup Plates {J} where needed.

## PART 5 — FINAL INSTALLATION PROCEDURES

1. Set the hitch on the Industry Standard Rails by centering the tabs on the bottom of the hitch into the slots on the rails.
2. Install the hitch pins through the side of the base rails to secure the hitch assembly to the base rails using the supplied pin clips.
3. Make certain the hitch comes on and off without binding prior to completing final torques.
4. Tighten all bolts, including the base rail bolts, according to the Torque Table below.

TORQUE TABLE	
3/8" bolt	— 31 ft. lbs.
1/2" bolt	— 75 ft. lbs.
5/8" bolt	— 151 ft. lbs.
3/4" bolt	— 266 ft. lbs.





*MANUFACTURED BY:*  
PULLIAM ENTERPRISES, INC.  
13790 East Jefferson Blvd.  
Mishawaka, IN 46545  
(574) 259-1520 • (800) 443-2307  
info@pullrite.com • www.pullrite.com