

## ULTRA 3000 ELECTRIC TONGUE JACK

### Installation/operation

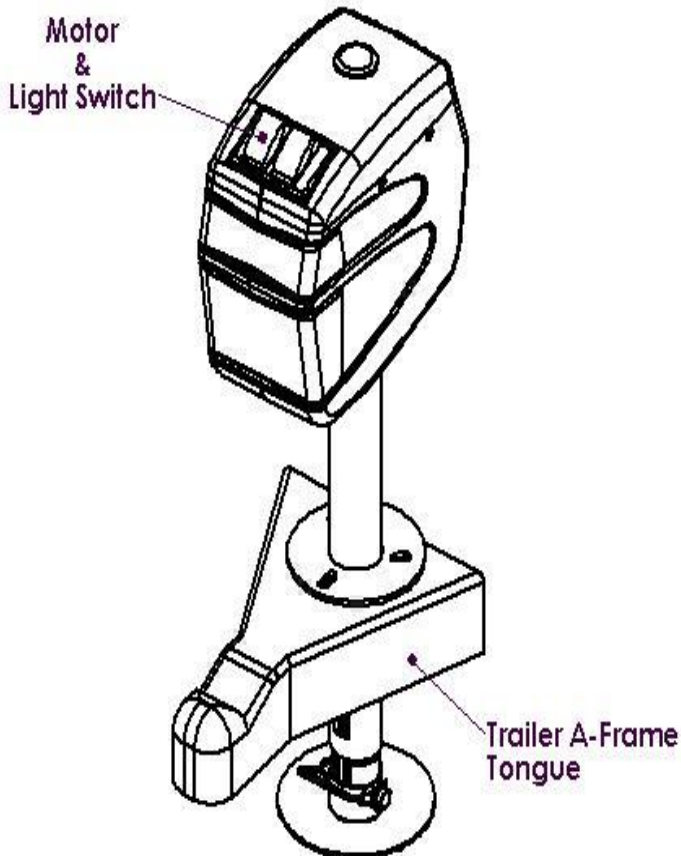

### Installation

1. Block the wheels and support the trailer "A" frame securely.
2. Remove the existing jack.

**Note:** Save the original bolts and washers for installing the Odyssey 3000 Electric Tongue Jack.

3. The Electric is internally grounded. Therefore for good electrical contact, clean well where the "A" frame comes into contact with the Tongue Jack Mounting Plate.
4. Install the Electric Tongue Jack using the original bolts and Star Lock washers supplied.
5. The Electric Tongue Jack was designed to replace an existing crank down jack.
6. Align the motor head so that the motor housing is facing the front of the "A" frame.
7. Install the Fuse Holder. Cut the red wire of the fuse in the middle and attach one end to the positive post of the 12 volt power supply. The other end will be connected to the black wire from the Tongue Jack.  
The connections can be made using either crimping connectors or by soldering.
8. Connect the green wire to the negative post of the battery.

**Warning:** When using an extension wire, DO NOT use smaller than # 10 gauge wire.

### Operation

1. Block trailer wheels securely.
2. The Ultra 3000 Odyssey Electric Tongue Jack is operated by means of the Toggle Switch located on top of the motor housing.
3. Extend the jack by holding the Toggle Switch in the extend position.

**CAUTION:** Release the Toggle Switch if the motor stalls. There is a circuit breaker to prevent motor damage, if the circuit breaker trips wait 15 seconds for it to reset before operating the jack.

4. Retract the jack by holding the Toggle Switch in the retract position. As the jack approaches the fully retracted position it will slow down and then stall. The Toggle Switch should be released at the first indication of slowing down.

**NOTE:** The end of the inner tube is painted red as a warning to stop before the jack hits the internal stop.

### Manual Operation

1. Disconnect the fuse, (unscrew and pull apart.)
2. Remove the cap plug on top of the jack.
3. Insert a 9/16 deep well socket (Supplied) into the hole and onto the end of the drive collar. Rotate the socket with a ratchet clockwise to retract and counter clockwise to extend.
4. When complete, remove socket and replace cap plug and reassemble the fuse connection.

### Application

The Ultra Odyssey 3000 Electric Tongue is a 12 volt motor-driven screw jack for the use on travel trailers and boat trailers.

### Specifications

Vertical load: 3000 lbs. continuous over full stroke with  
5000 lbs. instantaneous tongue breakaway  
capacity.

Travel - 18"

Fixed foot pad

Power requirements - 12 Volts D.C.

Outer tube - 2"

Inner tube 1 3/4"

Retracted Height - 27"

Removable foot pad 6" dia.

Approximate Shipping Weight 30 lbs.

# **ULTRA-FAB PRODUCTS, INC.**

## **THREE YEAR LIMITED WARRANTY**

### **THE MANUFACTURER NAMED BELOW MAKES THE FOLLOWING WARRANTY WITH RESPECT TO THE ULTRA POWER TWIN II STABILIZER, 5<sup>th</sup> WHEEL LANDING GEAR & ODYSSEY TONGUE JACK**

1. This Warranty is made only to the first Purchaser (hereinafter called the "Original Purchaser") who acquires this product for their own use.
2. This Warranty will be in effect for three years from the date of purchase by the Original Purchaser. It is suggested that the Original Purchaser retain a copy of the dated bill of sale as proof of purchase.
3. This Warranty covers only specified parts which shall be free from defects in material and workmanship under normal use. This Warranty does not cover conditions unrelated to the material and workmanship of the product. Such unrelated conditions include, but are not limited to (a) faulty installation and any damage resulting from such; (b) failure to follow Manufacturer's instructions for use of this product, and (c) any accident to, or misuse of, any part of this product and any alteration by anyone other than the Manufacturer or its authorized representative.
4. In order to obtain the benefits of this Warranty, you should return the product which you find defective to the Manufacturer named below, along with the proof of purchase, during the period that this Warranty is in effect. All charges incurred in delivery of the product to the Manufacturer, and in picking it up after the Warranty service has been completed, must be paid by the Original Purchaser.
5. Any item returned in the manner described in paragraph 4 will be examined by the Manufacturer. If it is found that the returned item was defective in material or workmanship, the Manufacturer will repair or replace the product, at their option, without charge for material or labor.
6. Ultra-Fab will pay freight on replacement parts during the first 90 days of ownership by the Original Purchaser.
7. The Manufacturer does not authorize any person or company to create any Warranty obligation or liability on their behalf.
8. NEITHER PARTY SHALL BE LIABLE FOR SPECIAL, INDIRECT, INCIDENTAL OR CONSEQUENTIAL DAMAGES. THE REMEDIES OF THE PURCHASER, AS SET FORTH HEREIN, ARE EXCLUSIVE, AND THE LIABILITY OF ULTRA-FAB PRODUCTS, INC. SHALL NOT EXCEED THE PRICE OF THE EQUIPMENT OR PART ON WHICH SUCH LIABILITY IS BASED.
9. SOME STATES DO NOT ALLOW THE EXCLUSION OR LIMITATION OF INCIDENTAL OR CONSEQUENTIAL DAMAGES, SO THE ABOVE LIMITATION MAY NOT APPLY TO YOU.
10. THIS WARRANTY GIVES YOU SPECIFIC LEGAL RIGHTS, AND YOU MAY ALSO HAVE OTHER RIGHTS WHICH VARY FROM STATE TO STATE.

ULTRA-FAB PRODUCTS, INC.  
57985 STATE ROAD 19, SOUTH  
ELKHART, IN 46517  
800-860-7571

# 2" LOWER STEM ASSEMBLY

NO.	QTY.	PART #	DESCRIPTION
1	1	38-751133	RETAINING RING COLLAR
2	1	38-751121	BEARING-OYDESSY
3	1	38-751153	KEY-COLLAR GEAR
4	1	38-751122	OYDESSY COLLAR
5	2	38-751138	PIN-COTTER
6	1	38-751127	PIN-UPPER
7	3	38-751126	WASHER-OYDESSY
8	6	38-751128	WASHER-BELLEVILLE
9	1	38-751130	JACKSCREW
10	1	38-751135	NUT-1.75 CAST
11	3	38-751139	SCREW-M6 X 10
12	1	38-751131	1.75" INNER TUBE
13	1	38-751129	PIN-LOWER JACKSCREW
14	1	38-751102	2" OUTER TUBE BLACK
15	4	38-751156	WASHER-M8
16	4	38-751155	BOLT-M8 X 25
17	1	38-751100	FOOTPAD-OYDESSY 3000
18	1	38-141023	PIN-LOCK 2 1/2"

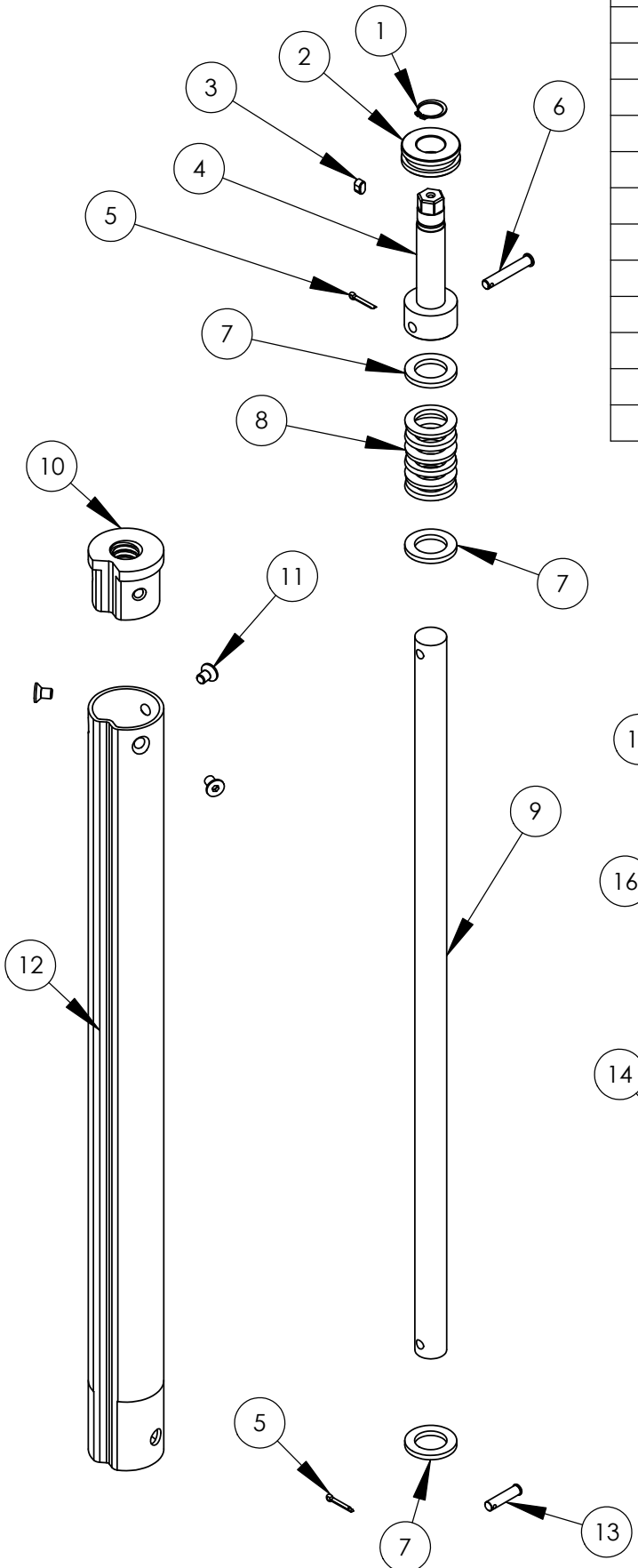

38-741160 - INNER TUBE ASSEMBLY  
(INCLUDES ITEMS 1 THRU 13)

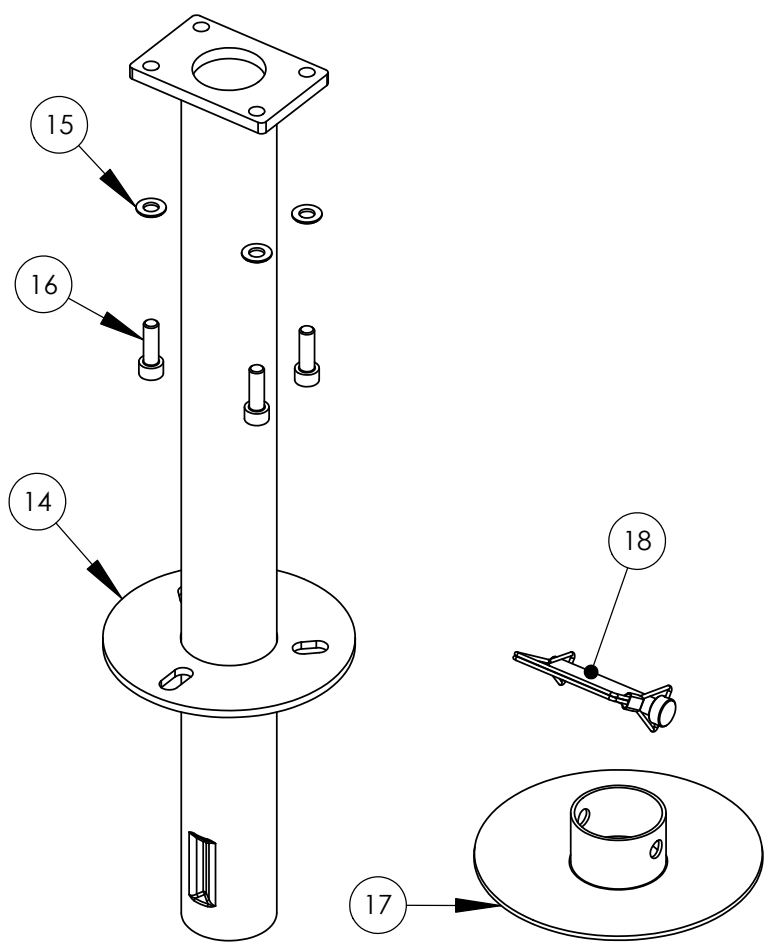

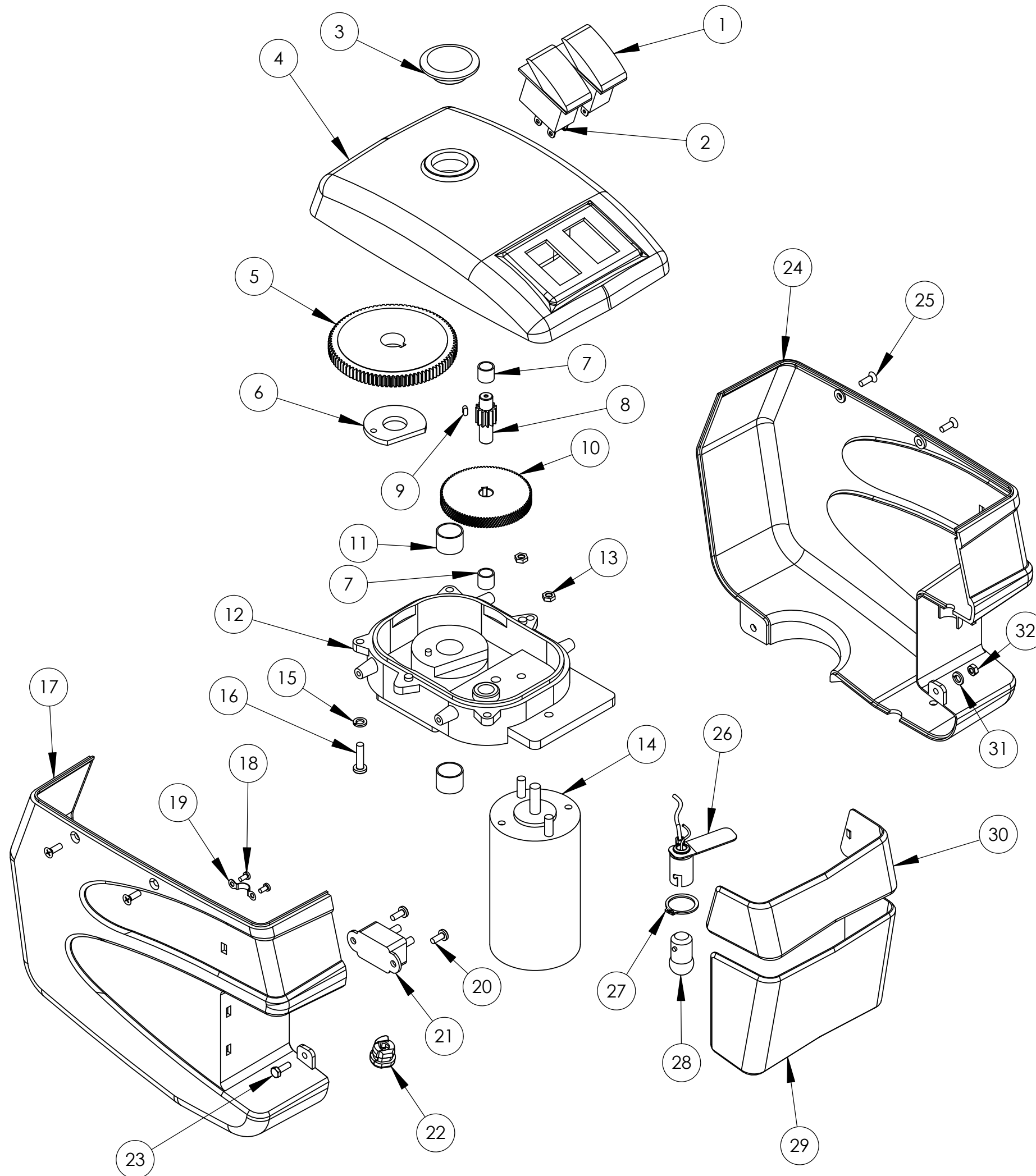

NO.	QTY.	PART #	DESCRIPTION
1	1	38-751113	LIGHT SWITCH
2	1	38-751112	MOTOR SWITCH
3	1	38-751114	TOP RUBBER PLUG
4	1	38-751119	COVER-MAIN HOUSING BLACK
5	1	38-751117	MAIN DRIVE GEAR
6	1	38-751123	THRUST WASHER
7	2	38-751149	BUSHING-SMALL
8	1	38-751124	PINION GEAR
9	1	38-751154	KEY-PINION
10	1	38-751118	SPUR GEAR
11	2	38-751148	BUSHING-LARGE
12	1	38-751116	MAIN GEAR HOUSING
13	2	38-751152	NUT-M5
14	1	38-751157	MOTOR-3000 OYDESSY
15	4	38-751151	WASHER-LOCK M5
16	4	38-751150	BOLT-M5 X 20
17	1	38-751108	COVER-RIGHT SIDE BLACK
18	4	38-751140	SCREW-ST2.9 X 6.5
19	2	38-751125	WIRE CLIP
20	2	38-751141	SCREW-ST4.2 X 9.5
21	1	38-751142	BREAKER-CIRCUIT
22	1	38-751143	RESTRAINT-WIRE
23	4	38-751144	SCREW-M4 X 12-N
24	1	38-751106	COVER-LEFT SIDE BLACK
25	4	38-751147	SCREW-CM4
26	1	38-751165	LIGHT HOLDER ASSEMBLY
27	1	38-751134	RETAINING RING LIGHT
28	1	38-751115	LIGHT BULB
29	1	38-751111	LIGHT LENS
30	1	38-751110	REFLECTOR-AMBER
31	4	38-751146	WASHER-LOCK M4
32	4	38-751145	NUT-M4-D-N

**Motor Gear Assembly  
38-751163  
Complete**