

# 4048 RV By-Pass Pump By SHURflo

## Installation & Maintenance Manual Installation Preparation

The goal of installation is to provide a quiet, easy-to-maintain installation with good flow and low backpressure. This can be accomplished with the following guidelines:

- Mount on a **solid surface** in an **accessible location** for strainer cleaning and pump maintenance.
- Use **flexible high-pressure hose** on the pump inlet and outlet [such as SHURflo Kit 94-591-01]. The pumps ports and strainer **should not be connected to plastic or rigid pipe, or the pump's normal motion will transmit through rigid plumbing causing noise, and possibly loosening or cracking components.**
- Pump must use an adequate 50-mesh **strainer** [such as SHURflo 255 series strainers].
- Use a minimum of **1/2" [13mm] Inner Diameter** plumbing. Smaller ID plumbing will cause cavitation, high backpressure, low flow and noise.
- **No need for an accumulator** with by-pass pumps.
- Pump is designed for **intermittent duty** only: Do not use these pumps for running a Reverse-Osmosis [RO] Filtration System. High pressure-continuous duty usage will shorten the life of the pump and is not covered under warranty.
- Wire Size is 14 GA [2.5mm<sup>2</sup>] **MINIMUM**, 12GA [4mm<sup>2</sup>] is recommended---**See Wire Chart** in Electrical Section for minimum sizing.
- Minimum power requirement is a 15 Amp circuit.
- **Reduce restrictions on inlet and outlet.** This includes small inner diameter shut-off valves, winterizing valves and elbows.
- **If** the RV has an **Intellitec Pump Controller**, it must be rated at 15 amps; If the controller is rated at 7.5 or 10 Amps, a new controller or a high-amp relay must be used.

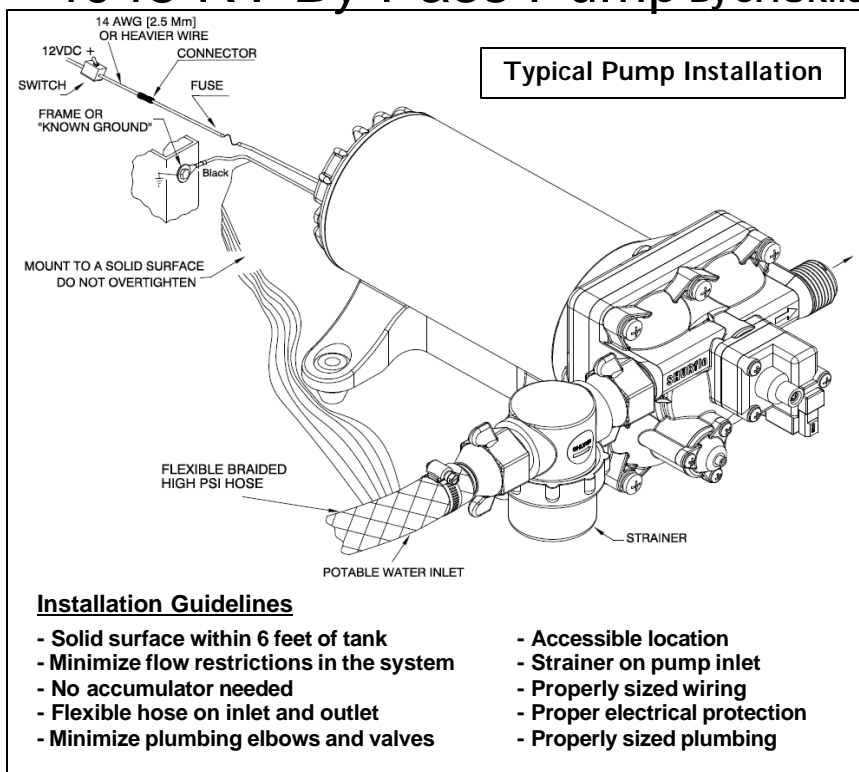

## Mounting

- Mount the pump within 6 feet of the tank for best performance and pump life. The pump will pull farther, but the farther it pulls the more work it does, increasing vibration and noise, and reducing the output and pump life.
- Mount pump in a space of at least 1 cubic foot for adequate ventilation to prevent overheating.
- Pump may be mounted in any position.
- Mount pump for easy access for cleaning strainer, maintenance and service.
- Mount pump on a solid surface to prevent vibration and noise.

## Electrical

- The pump works best on an individual filtered circuit, protected by the recommended fuse or breaker specified on the label.
- A 15-Amp switch is recommended and should be on the positive lead.

Minimum Wire Size for a 10% voltage drop on a 12VDC, 15 Amp Circuit. Length is the distance from the power source to pump and back to ground.

Feet [Meters]		AWG [mm <sup>2</sup> ]	
0 to 20	[0 to 6]	14	[2.5]
20 to 50	[6 to 15]	12	[4]
50 to 70	[15 to 21]	10	[6]
70 to 100	21 to 30]	8	[8]

- **Wire Sizing:** Proper wire sizing is required for good pump operation. If the wire is too small, low voltage will affect the pump performance and can create a fire hazard. **SHUT OFF POWER TO THE PUMP WHEN LEAVING THE RV UNATTENDED.**

### Plumbing

Installation of a strainer is required to prevent debris from entering the pump. For noise and vibration reduction we recommend at least 18 in. [.5 M] of 1/2" [13mm] I.D. flexible high-pressure hose to both ports. The pump ports and strainer **should not** be connected to plastic or rigid pipe. This hose should be anchored where it meets the hard plumbing to reduce plumbing vibration.

### Operation

This pump is designed for intermittent duty only. The pump operates normally up to about 30-psi, where a spring-loaded by-pass valve opens, allowing flow back from the output side to the input side, providing smooth, steady flow with virtually no cycling, all the way down to a trickle. As a faucet is opened back up, the pressure will drop, the by-pass will close and full flow is again obtained. This allows good flow, even with today's restrictive showers and pullout sprayer faucets. Performance will vary, of course, depending on the voltage to the pump; lower voltage = lower flow, higher voltage = higher flow. Remember your electrical safety: It is always best to shut power to the pump OFF when leaving the RV unattended.

**About the By-Pass NOTE: By-pass adjustment should only be performed by a professional technician with proper gauges and equipment.** The by-pass is a spring loaded diaphragm that opens up allowing water from the discharge side back to the inlet side. The by-pass is set to begin opening at about 30 psi and creating full by-pass at about 65 psi. The pressure switch on the pump is set to shut off at 55 psi. If the switch or by-pass are adjusted too much, the by-pass and switch shut-off can overlap and **THE PUMP WILL NOT SHUT OFF**. Screwing the switch screw in clockwise will raise the shut-off pressure. Unscrewing the switch screw counterclockwise will lower the pump shut-off pressure. Screwing the by-pass screw in will raise the pressure at which the by-pass starts and raise the full by-pass pressure. Unscrewing the by-pass screw counterclockwise will lower the pressure at which by-pass starts and lower the full by-pass pressure. **WARNING: If full by-pass is reached before the shut-off setting, the pump will not shut off.** Full by-pass pressure setting should be at least 10 psi higher than pump shut off pressure.

### Maintenance

Normal pump maintenance is all that is needed: Checking and cleaning of the strainer, normal sanitizing and winterizing and occasionally checking all plumbing hardware and fittings for tightness. Lack of sanitizing is the number one reason for premature pump failure and poor performance over time. Lack of sanitizing will cause scale build-up on the diaphragm and valves, causing low flow and leak back [occasional pump cycling with no faucets open or tank filling up when hooked up to city water].

### Sanitizing

Potable water systems require periodic maintenance to keep components working properly and deliver a consistent flow of fresh water. Sanitizing is recommended: prior to storing, after a period of storage, or any time the system is opened or contaminated, as follows: **NOTE: Check your Vehicle Owner's Manual for specific instructions. By-pass any filters or remove filter cartridges.**

1. Determine the amount of common household bleach needed to sanitize the tank.  
A) 2 ounces of bleach per 15 gallons tank size: 60 gallon tank [15 x 4] = 4 x 2 ounces = 8 ounces of bleach.  
B) 1 ml bleach per 1 liter tank size: 300 liter tank = 300 milliliters of bleach.
2. Mix the bleach with water in a container such as a gallon jug. If tank is filled through a pressurized fitting, pour the bleach into the hose before attaching the hose to the city water entry.
3. Pour the bleach solution into the tank and fill the tank with potable water. Rock the RV back and forth to coat top and sides of potable water tank.
4. Open **all** faucets (Hot & Cold) allowing the water to run until the odor of chlorine is detected. Allow four (4) hours of contact time to disinfect completely. Doubling the solution concentration allows for a contact time of one (1) hour.

5. Drain the tank. Refill the tank and flush the system once or twice until the odor has decreased. The residual chlorine odor and taste is not harmful.

**Winterizing Refer to the vehicle owner's manual for specific winterizing instructions.**

If water is allowed to freeze in the system, serious damage to the plumbing and pump may occur. Failures of this type will void the warranty. The best guarantee against damage is to completely drain the pump and perform the following:

1. Drain the water tank. If the tank doesn't have a drain valve, open all faucets allowing the pump to operate until the tank is empty.
2. Open all the faucets (including the lowest valve or drain in the plumbing), allow the pump to purge the water from the plumbing, and then turn the pump OFF.
3. Using a pan to catch the remaining water, remove the plumbing at the pump's inlet/outlet ports. Turn the pump ON, allowing it to operate until the water is expelled. Turn OFF power to the pump once the plumbing is emptied. Do not reconnect the pump plumbing. Make a note at tank filler as a reminder: "Plumbing is disconnected".
4. All faucets must be left open to guard against any damage.
5. Potable anti-freeze may be poured down drains and toilets to protect p-traps and toilet seals. Sanitize the plumbing system before putting the plumbing system back in service.

**Troubleshooting:**

**Vibration induced by driving can loosen plumbing, strainers and pump hardware. Check for system components that are loose. Also, refer to the chart below for trouble-shooting tips.**

**PUMP WILL NOT START / BLOWS CIRCUIT:**

- ✓ Electrical connections, fuse or breaker, main switch, and ground connection.
- ✓ Is the motor hot? Thermal breaker may have triggered; it will reset when cool.
- ✓ Is voltage present at the switch? Bypass pressure sw. Does the pump operate?
- ✓ Charging System for correct voltage ( $\pm 10\%$ ) and good ground.
- ✓ For an open or grounded circuit, or motor; or improperly sized wire.
- ✓ For seized or locked diaphragm assembly (water frozen?).

**WILL NOT PRIME / SPUTTERS: (No discharge/Motor runs:**

- ✓ Is the strainer clogged with debris?
- ✓ Is there water in the tank, or has air collected in the hot water heater?
- ✓ Is the inlet tubing/plumbing sucking in air at plumbing connections (vacuum leak)?
- ✓ Is inlet/outlet plumbing severely restricted or kinked? Restrictive valves?
- ✓ Proper voltage with the pump operating ( $\pm 10\%$ ).
- ✓ For debris in pump inlet/outlet valves or swollen/dry valves.
- ✓ Pump housing for cracks or loose drive assembly screws.

**RAPID CYCLING:**

- ✓ For restrictive plumbing and flow restrictions in faucets/shower heads.
- ✓ Water filter/purifier should be on separate feed line.
- ✓ Shut-off pressure set too low.

**PUMP WILL NOT SHUT-OFF / RUNS WHEN FAUCET IS CLOSED:**

- ✓ Output side (pressure) plumbing for leaks, and inspect for leaky valves or toilet.
- ✓ For air trapped in outlet side (water heater) or pump head.
- ✓ For correct voltage to pump ( $\pm 10\%$ ).
- ✓ For loose drive assembly or pump head screws.
- ✓ Are the valves held open by debris or is the rubber swollen?
- ✓ Pressure switch operation. By-pass set higher than shut-off.

**NOISY OR ROUGH OPERATION:**

- ✓ For plumbing which may have vibrated loose.
- ✓ For a restricted inlet (clogged strainer, kinked hose, restrictive valves).
- ✓ Is the pump plumbed with rigid pipe causing noise to transmit?
- ✓ Does the mounting surface amplify noise (flexible)? Does it bang like a drum?
- ✓ For mounting feet that are loose or are compressed too tight.
- ✓ For air in the system. Check all fixtures for air and bleed system.
- ✓ The motor with pump head removed. Is noise from motor or pump head?

**LEAKS FROM HEAD OR SWITCH:**

- ✓ For loose screws at switch, by-pass or pump head.
- ✓ Switch diaphragm ruptured or pinched.
- ✓ For punctured diaphragm if water is present in the drive assembly.

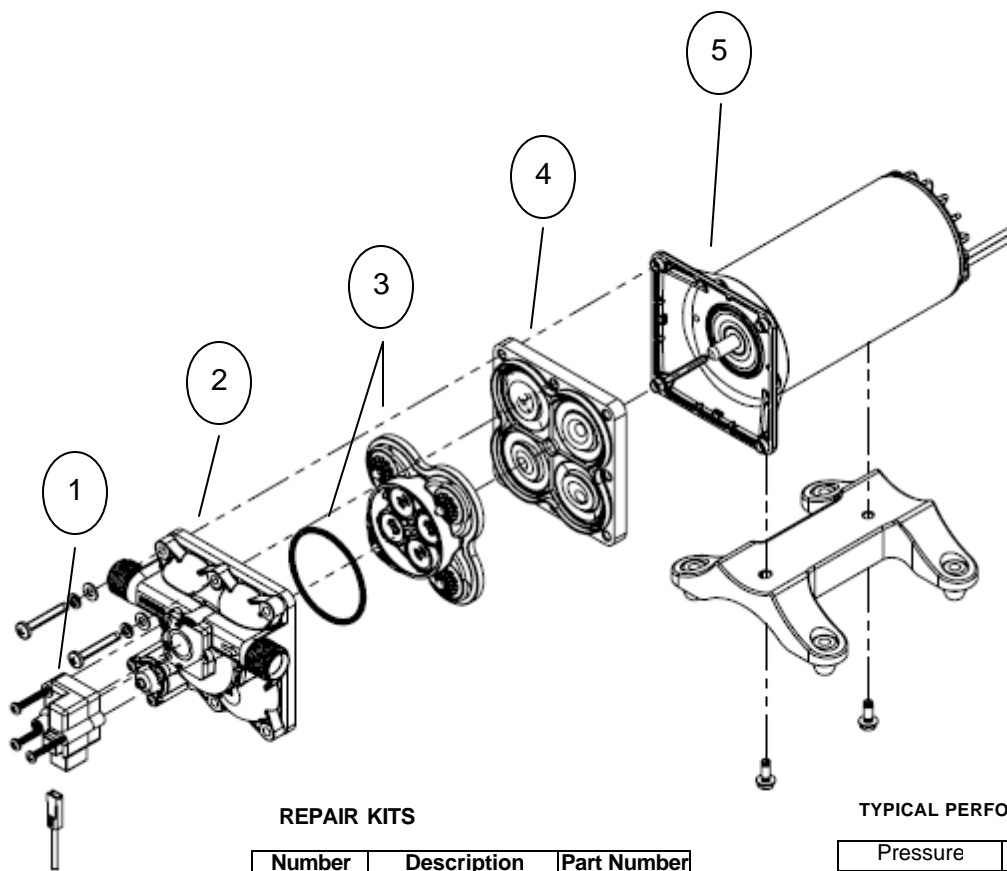

**REPAIR KITS**

Number	Description	Part Number
1	Pressure Switch*	94-801-05
1,2	Upper Assembly*	94-801-01
3	Valve Assembly	94-800-01
4	Drive Assembly	94-801-02
5	Motor	94-71-001-07
1,2,3,4	Pump Head*	94-801-02
Not Showr	Check Valve	94-800-03

\*With Preset Switch and By-Pass Adjustment

**TYPICAL PERFORMANCE**

Pressure	Flow		Current		
	PSI	Bars	GPM	LPM	Amps
0	0		4.0	15.1	3.0
10	0.68		3.5	13.2	4.5
20	1.37		3.2	12.1	6.0
30	2.06		2.8	10.5	7.0
40	2.75	1.75	6.62		8.0
50	3.44	0.8	3		9.0

**LIMITED WARRANTY**

SHURflo warrants its aftermarket retail 4048 series potable water pumps to be free from material and workmanship defects under normal use and service for 2 years from the date of purchase with purchase receipt or 2 years from the date of manufacture indicated on the motor nameplate if no purchase receipt is available, as outlined in document MS-030-152. Pumps installed as original equipment are warranted for 1 year, and fall under the warranty supplied by the manufacturer, as outlined in document MS-030-123. This limited warranty is in lieu of all other warranties, expressed or implied (including without limitation implied warranties of merchantability and fitness for a particular purpose), and no other person is authorized to give any other warranty or assume obligation or liability on SHURflo's behalf. SHURflo shall not be liable for any labor, damage or other expense, nor shall SHURflo be liable for any indirect, incidental or consequential damages of any kind incurred by the use or sale of any defective Product or part. This limited warranty covers Products distributed within the United States of America and Canada. Other world market areas should consult with the distributor for any deviation from this document. The limited warranty will not apply to pumps that were improperly installed, misapplied, or are incompatible with components not manufactured by SHURflo. Product failure due to foreign debris is not covered under the terms of this limited warranty. SHURflo will not warrant any Product that is physically damaged, or altered outside SHURflo. Warranty claims may be resolved by an authorized dealer service center, or by a SHURflo service center. Returns are to be shipped with charges pre-paid. Package all returns carefully. SHURflo will not be responsible for freight damage incurred during shipping to a service center. For complete Limited Warranty details, consult SHURflo.

*SHURflo reserves the right to update specifications, prices or make substitutions without notice*

**SHURflo**  
 52748 Park Six Court  
 Elkhart, Indiana 46514-5427  
 Toll Free: (800) 854-3218  
 Fax: (574) 264-2169

**SHURflo Europe, Middle East, Africa**  
**Pentair Water Belgium bvba**  
 B-2200 Herentals, Belgium  
 Phone: +32-14-283500  
 Fax: +32-14-283505

Visit our Website at [www.shurflo.com](http://www.shurflo.com)

