

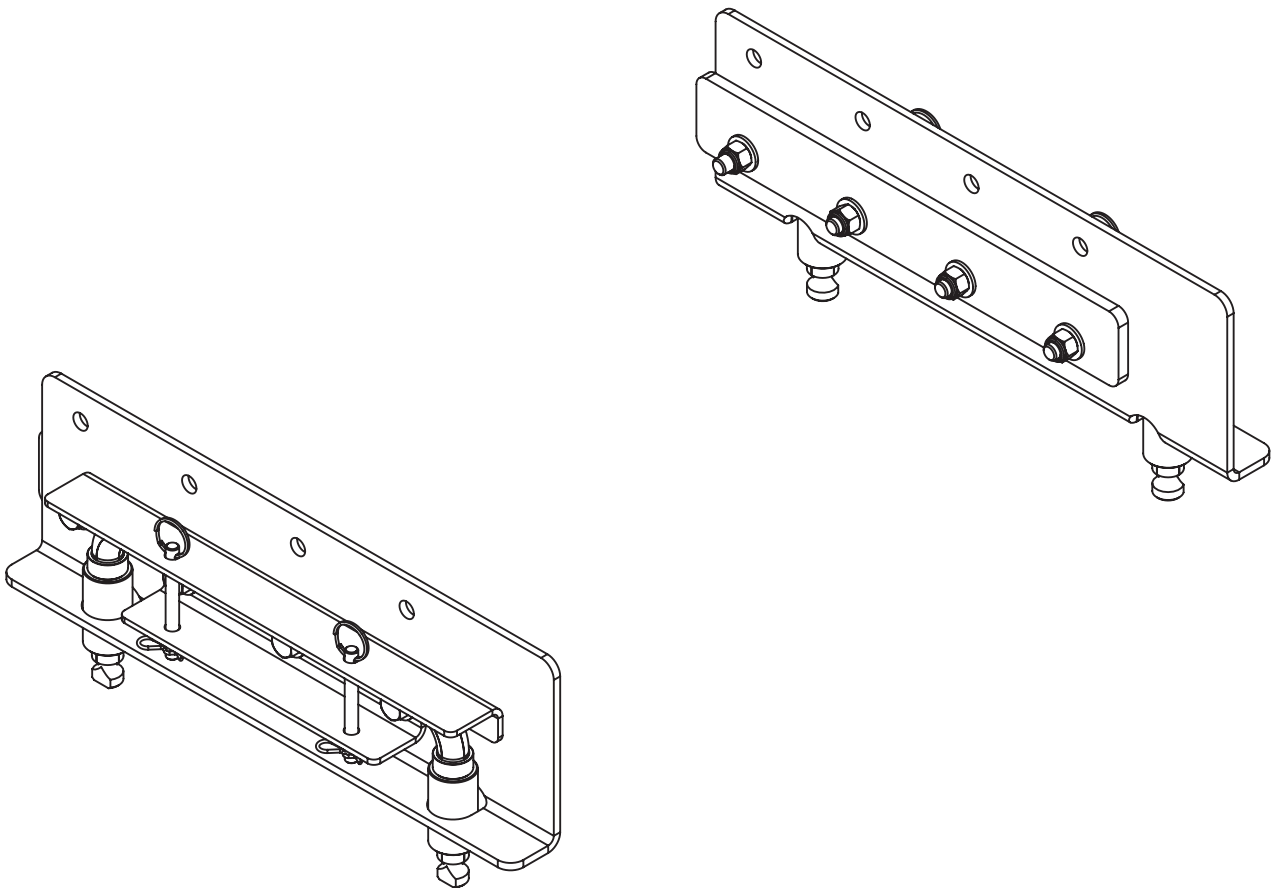

# Demco

## 5th Wheel Side Rail Assemblies

### 6004 UMS SIDE RAIL



**READ** *complete manual CAREFULLY  
BEFORE attempting operation.*

Doing Our Best to Provide You the Best

MANUAL  
OPERATORS

## 6004 Side Rail Assembly Instructions

1. Loosely bolt the main Autoslide assembly to the side rails with spacer plates using the 1/2" x 1 3/4" bolts, flat washers, and lock nuts provided in the side rail bolt package at the predetermined height using the bolt pattern guide in below. **NOTE:** On highest setting, use 6 bolts. The 4 along the top row are to fasten to hitch assembly and the bottom 2 are to fasten the side rail brace to side rail to retain locking pins. (1/4" & 3/8" thick spacers are supplied for adjusting the hitch mount width with the bed pockets. You may mix and match the different shim thicknesses for fine tuning the fit).
2. Tighten all bolts.
3. Unlock locking pins and insert the hitch assembly into the base rails and test for fit. If the pins are too narrow to drop in, follow the alignment procedure on page 3.
4. Proceed to base rail install procedure as provided in the base rail installation kit.

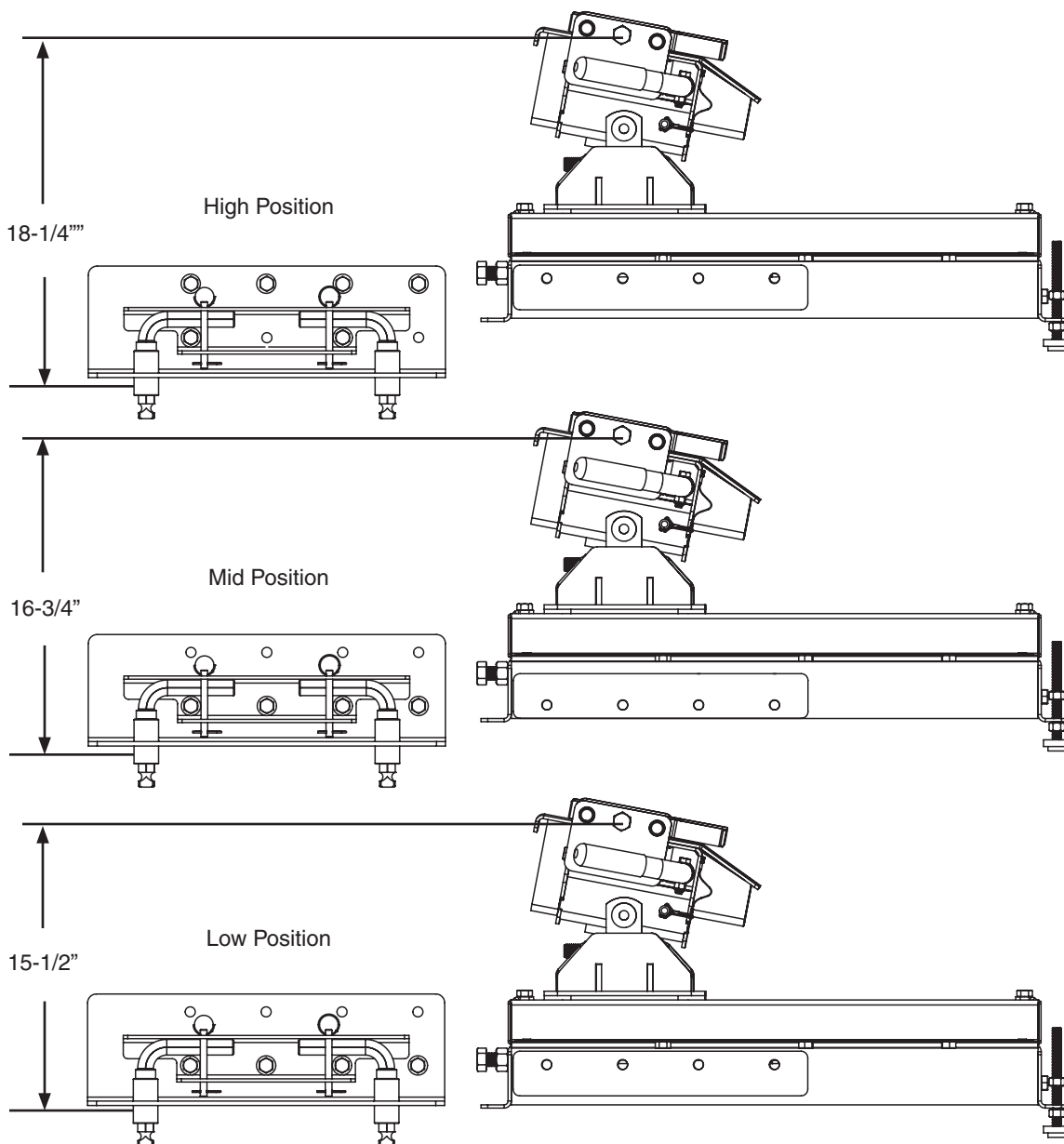

## 6004 Parts Breakdown

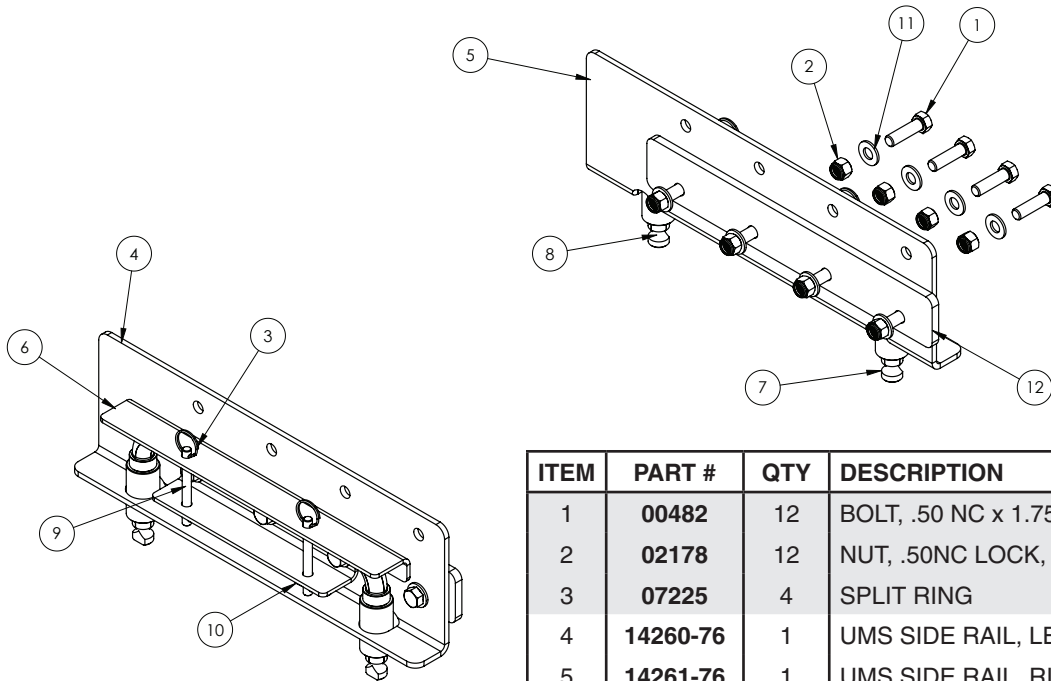

ITEM	PART #	QTY	DESCRIPTION
1	00482	12	BOLT, .50 NC x 1.75 GR.5 HEX
2	02178	12	NUT, .50NC LOCK, NY. INSERT
3	07225	4	SPLIT RING
4	14260-76	1	UMS SIDE RAIL, LEFT
5	14261-76	1	UMS SIDE RAIL, RIGHT
6	14262-76	2	UMS SIDE RAIL BRACE
7	14263-95	2	UMS LOCK PIN ASSEMBLY, RIGHT
8	14264-95	2	UMS LOCK PIN ASSEMBLY, LEFT
9	14342-95	4	CLEVIS SAFETY PIN
10	14350	4	HAIR PIN, .093 WIRE X 1.63 OL
11	14488	20	.50 FLAT WASHER
12	14763-76	2	.375 AS SPACER
12	14959-76	2	.25 AS SPACER

Please order replacement parts by **PART NO.** and **DESCRIPTION**

**IMPORTANT NOTE:** Apply a little grease or lubricant to the part of the pins that insert into the base rails to help maintain smooth operation and rotation of pins and to protect from the elements. Turn the pins occasionally to prevent them from seizing.

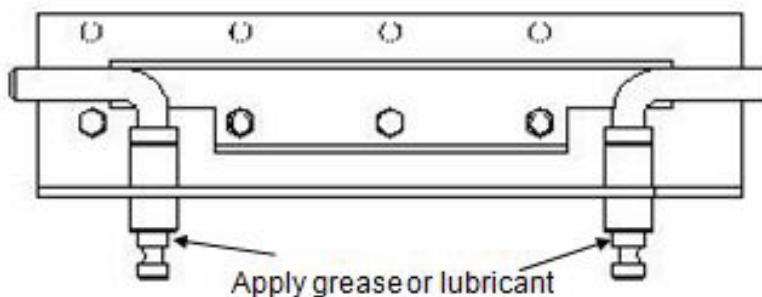

## Alignment Procedure

If the side plate pins do not drop into the base rail holes because they are not out far enough, then undo one side and add a 1/2" flat washer in between the main frame and the side spacer plate at each bolt attachments hole. Tighten and try reinstalling into the base rails. If necessary, do the same on the other side to shim out further if needed.

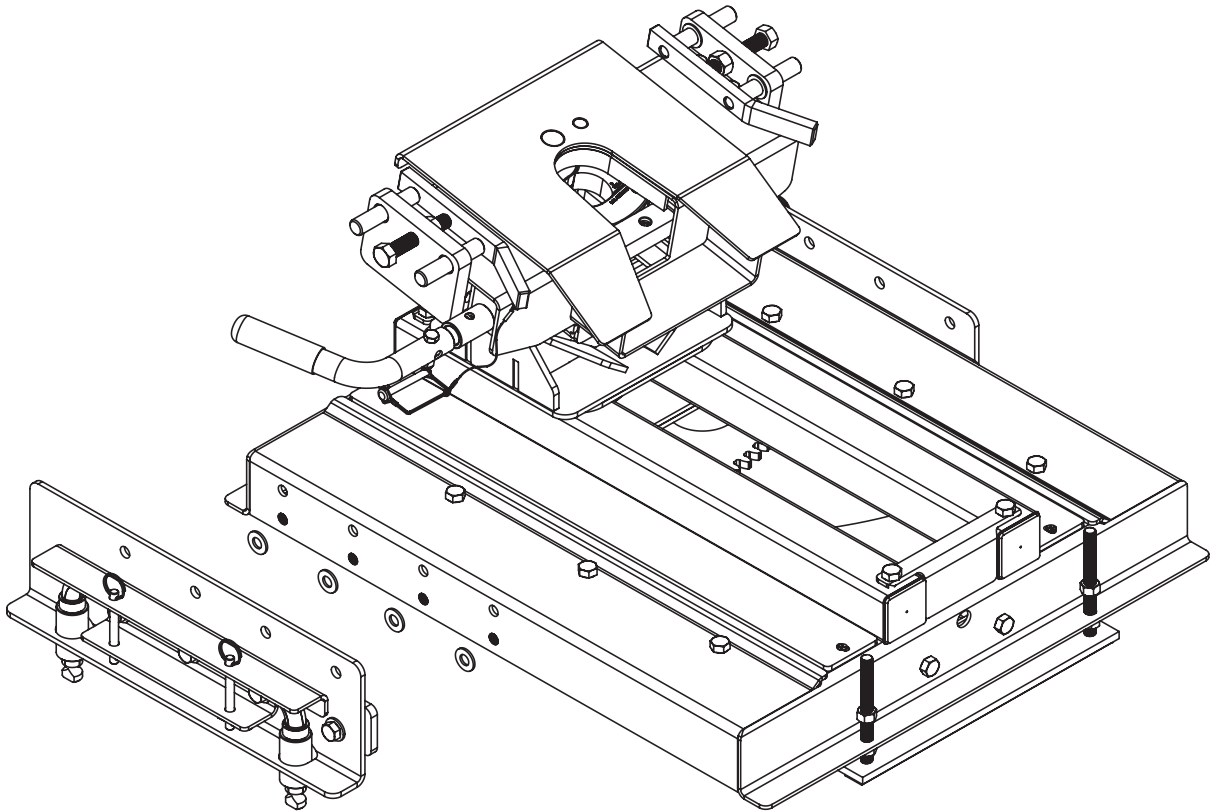

**Demco**

P.O. BOX 189  
4010 320th St., BOYDEN, IA. 51234  
PH: (712) 725-2311  
FAX: (712) 725-2380  
TOLL FREE: 1-800-54DEMCO (1-800-543-3626)  
[www.towdemco.com](http://www.towdemco.com)